

**KiloWood® 千木®**

**成都成林数控刀具股份有限公司**  
**液压夹头刀柄**

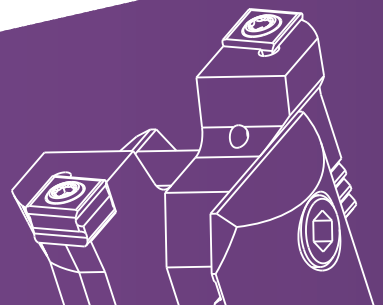

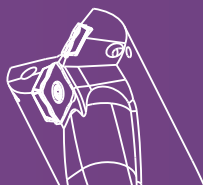
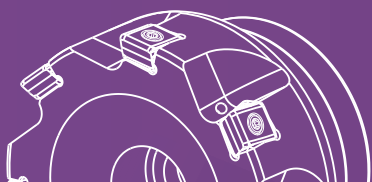

## **Kilowood**<sup>®</sup> 企业文化：包容、成长、希望.....

每一粒种子都蕴含着千木成林的诺言，但是不能把种子储存起来，必须还之于肥沃的土地。

给予越多, 获得越丰富。

我们能带给您：

大幅度提高生产率，缩短加工时间

减少刀具浪费以降低成本

充分释放生产潜力

提高企业在行业中的竞争力



公司简介

我们迈向更多元化的未来.....

## ● 液压夹头刀柄



# 液压夹头刀柄

## 特点与优势

稳定可靠的高精度夹持  
满足多直径多长度选择  
使用操作方便可靠

## ● 液压夹头刀柄

# 液压夹头刀柄系列总览



### 标准型：

卓越的夹持精度，稳定的夹持力，适于多种工况，包括HSK、7:24等多种接口，调节方便，丰富多样。



### 细长型：

细长刀体设计，易于控制干涉，实现模具深腔粗、精加工。



### 车床、走心机专用液压刀柄：

用于车床、走心机，夹持钻头、铣刀、定心钻、小镗刀等，拆装方便。



(非标定制)

### 强力型：

应用于重载加工工况，装夹换刀快速方便，高速高刚性刀柄，特别适合组合铰削加工等存在大轴向力的工况。

## ● 液压夹头刀柄



(非标定制)

### 杆型：

细长的外型，可与各种型式和长度的刀柄搭配，应用场景灵活多变。



(非标定制)

### 笔型：

外型比杆型更加纤细，夹持力更大，一般用与深腔钻、铰加工。



### 法兰型：

功能实用性强，通过径向调节螺钉调节刀具跳动，装刀后可调节刀具轴向长度，应用灵活。



### 卡簧：

配合高精度卡簧实现多种柄部直径刀具夹持。

## ● 液压夹头刀柄

### 刀具高精度夹持的完美选择

- 卓越的夹持精度
- 稳定可靠的夹持力
- 满足多种工况加工
- 包括HSK/7:24等多种接口
- 仅需一把扳手，调节方便快捷



### 卓越的夹持精度

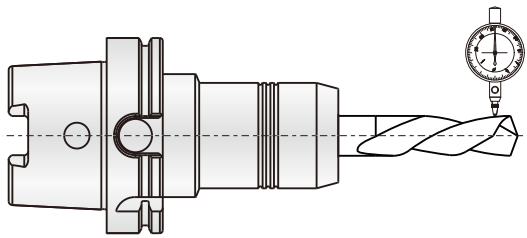

2.5倍径（最长不超过50mm）处跳动小于3um，有效提高加工表面质量及刀具使用寿命。

### 稳定可靠的夹持力

螺旋内腔均匀变形获得可靠的夹持力。

圆柱周边受力图

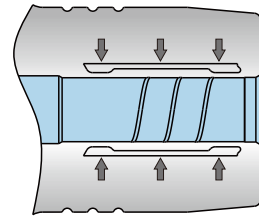

### 可实现中心冷却及轴向调节

中心冷却可以延长刀具寿命，有效节约刀具成本。

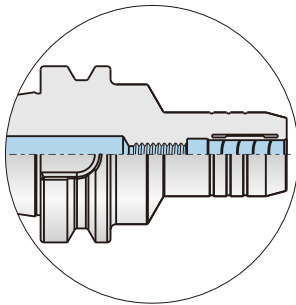

**⚠ 禁止在未装入刀具的情况下拧紧压紧螺钉。**

### 高动平衡性

采用静平衡设计及动平衡检测。



### 包括HSK/7:24等多种接口

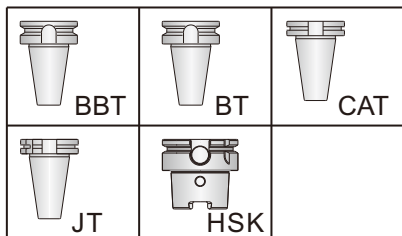

### 多用途加工



不推荐夹持柄部带扁刀具。

## ● 液压夹头刀柄

配合高精度卡簧实现多种夹持



操作简便 快速换刀



仅需一把扳手操作即可实现刀具快速更换。

应用场合

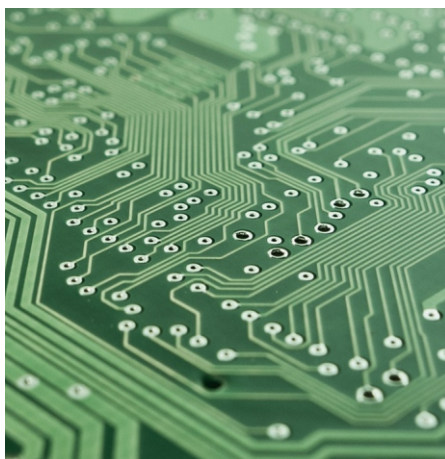

电子信息



汽车



工程机械



通用机械



飞机

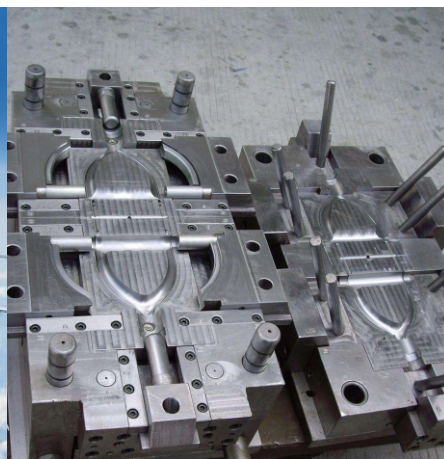

模具

# D 工具系统 Tool System

## 液压夹头刀柄-HSK63A Hydraulic Chucks

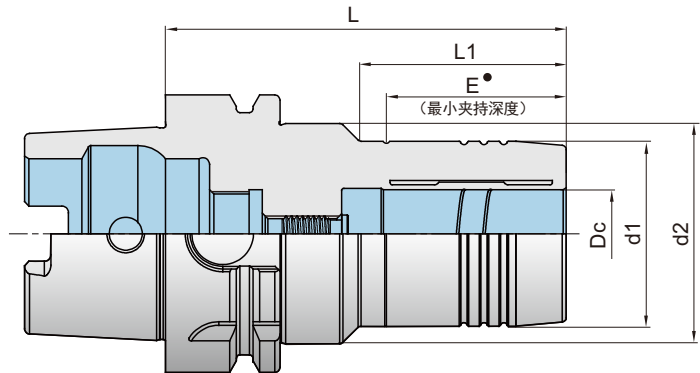
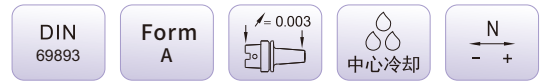

型号 Type	库存 Stock	锥柄型式 Taper type	尺寸(mm) Dimension					轴向调节螺钉 Axial adjustment screw	加压螺钉 Locking Screw	卡簧 HC collet	扳手 Wrench	重量 (kg)
			Dc	d1	d2	L1	L					
HSK63A-KHC06-80	●	HSK63A	6	26	50	28	80	SHC050150	SHE100130	-	TS5Z	
HSK63A-KHC08-80	●	HSK63A	8	30	50	30	80	SHC060150	SHE100130	-	TS5Z	
HSK63A-KHC10-80	●	HSK63A	10	32	50	34	80	SHC080150	SHE100130	-	TS5Z	
HSK63A-KHC12-85	●	HSK63A	12	34	50	40	85	SHC080150	SHE100130	HC12	TS5Z	
HSK63A-KHC14-90	●	HSK63A	14	36	50	46	90	SHC080150	SHE100130	-	TS5Z	
HSK63A-KHC16-90	●	HSK63A	16	38	50	44	90	SHC080150	SHE100130	-	TS5Z	
HSK63A-KHC18-90	●	HSK63A	18	40	50	45	90	SHC080150	SHE100130	-	TS5Z	
HSK63A-KHC20-90	●	HSK63A	20	42	50	47	90	SHC080150	SHE100130	HC20	TS5Z	
HSK63A-KHC20-150	●	HSK63A	20	42	50	107	150	SHC080150	SHE100130	HC20	TS5Z	
HSK63A-KHC20-200	●	HSK63A	20	42	50	157	200	SHC080150	SHE100130	HC20	TS5Z	
HSK63A-KHC25-120	●	HSK63A	25	57	66	57	120	SHC080150	SHE100130	-	TS5Z	
HSK63A-KHC32-125	●	HSK63A	32	64	75	59	125	SHC100150	SHE100130	HC32	TS5Z	

接受带芯片孔刀柄订货, 订货示例: HSK63A-KHC06-80(IC)  
Tool holders with chip hole are available, order example: HSK63A-KHC06-80(IC)

● 常备库存 Unallocated stock    ● 可备库存 Available stock    ○ 订单生产 Order production

● 最小夹持深度详见27页

# D 工具系统 Tool System

## 液压夹头刀柄-HSK100A Hydraulic Chucks

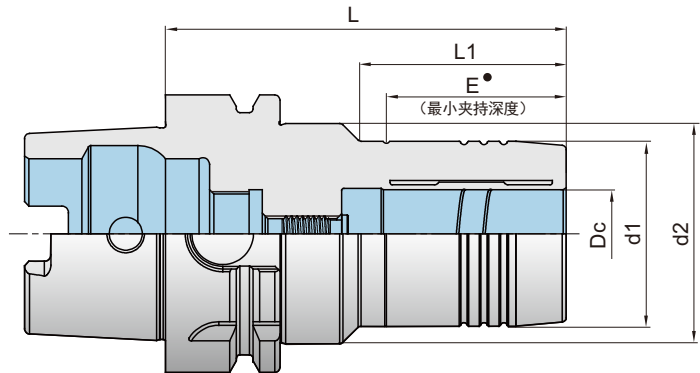
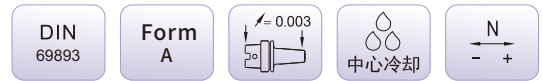

型号 Type	库存 Stock	锥柄型式 Taper type	尺寸(mm) Dimension					轴向调节螺钉 Axial adjustment screw	加压螺钉 Locking Screw	卡簧 HC collet	扳手 Wrench	重量 (kg)
			Dc	d1	d2	L1	L					
HSK100A-KHC06-80	●	HSK100A	6	26	50	30	80	SHC050150	SHE100130	-	TS5Z	
HSK100A-KHC08-80	●	HSK100A	8	30	50	31	80	SHC060150	SHE100130	-	TS5Z	
HSK100A-KHC10-90	●	HSK100A	10	32	50	38	90	SHC080150	SHE100130	-	TS5Z	
HSK100A-KHC12-95	●	HSK100A	12	34	50	44	95	SHC080150	SHE100130	HC12	TS5Z	
HSK100A-KHC16-100	●	HSK100A	16	38	50	51	100	SHC080150	SHE100130	-	TS5Z	
HSK100A-KHC20-105	●	HSK100A	20	42	50	58	105	SHC080150	SHE100130	HC20	TS5Z	
HSK100A-KHC20-150	●	HSK100A	20	42	50	103	150	SHC080150	SHE100130	HC20	TS5Z	
HSK100A-KHC20-200	●	HSK100A	20	42	50	153	200	SHC080150	SHE100130	HC20	TS5Z	
HSK100A-KHC25-110	●	HSK100A	25	57	66	64	110	SHC080150	SHE100130	-	TS5Z	
HSK100A-KHC32-110	●	HSK100A	32	64	75	63	110	SHC100150	SHE100130	HC32	TS5Z	

接受带芯片孔刀柄订货, 订货示例: HSK100A-KHC06-80(IC)  
Tool holders with chip hole are available, order example: HSK100A-KHC06-80(IC)

● 常备库存 Unallocated stock    ● 可备库存 Available stock    ○ 订单生产 Order production

● 最小夹持深度详见27页

# D 工具系统 Tool System

## 液压夹头刀柄-BT30 Hydraulic Chucks

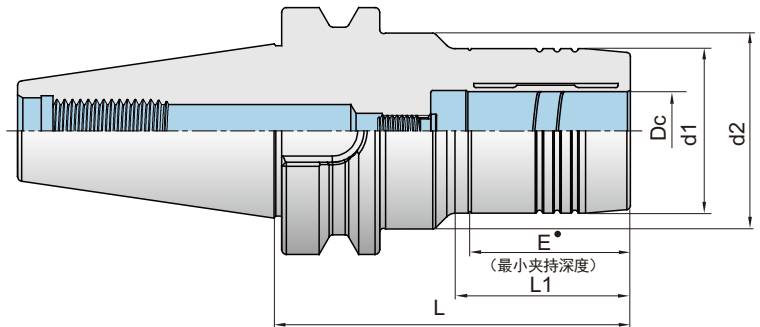
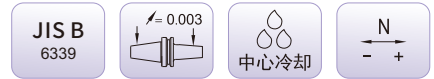

型号 Type	库存 Stock	锥柄型式 Taper type	尺寸(mm) Dimension					轴向调节螺钉 Axial adjustment screw	加压螺钉 Locking Screw	卡簧 HC collet	扳手 Wrench	重量 (kg)
			Dc	d1	d2	L1	L					
BT30-KHC06-75	●	BT30	6	26	50	30	75	SHC050150	SHE100130	-	TS5Z	
BT30-KHC08-75	●	BT30	8	30	50	31	75	SHC060150	SHE100130	-	TS5Z	
BT30-KHC10-80	●	BT30	10	32	50	37	80	SHC080150	SHE100130	-	TS5Z	
BT30-KHC12-85	●	BT30	12	34	50	42	85	SHC080150	SHE100130	HC12	TS5Z	
BT30-KHC16-90	●	BT30	16	38	50	49	90	SHC080150	SHE100130	-	TS5Z	
BT30-KHC20-90	●	BT30	20	42	50	51	90	SHC080150	SHE100130	HC20	TS5Z	

订货示例: BT30-KHC06-75  
Order example: BT30-KHC06-75

- 最小夹持深度详见27页

● 常备库存  
Unallocated stock

◐ 可备库存  
Available stock

○ 订单生产  
Order production

# D 工具系统 Tool System

## 液压夹头刀柄-BT40 Hydraulic Chucks

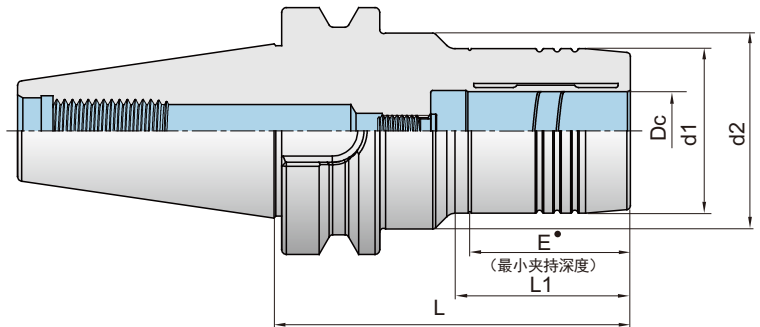
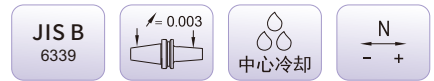

型号 Type	库存 Stock	锥柄型式 Taper type	尺寸(mm) Dimension					轴向调节螺钉 Axial adjustment screw	加压螺钉 Locking Screw	卡簧 HC collet	扳手 Wrench	重量 (kg)
			Dc	d1	d2	L1	L					
BT40-KHC06-90	●	BT40	6	26	50	36	90	SHC050150	SHE100130	-	TS5Z	
BT40-KHC08-90	●	BT40	8	30	50	40	90	SHC060150	SHE100130	-	TS5Z	
BT40-KHC10-90	●	BT40	10	32	50	41	90	SHC080150	SHE100130	-	TS5Z	
BT40-KHC12-90	●	BT40	12	34	50	42	90	SHC080150	SHE100130	HC12	TS5Z	
BT40-KHC14-90	●	BT40	14	36	50	43	90	SHC080150	SHE100130	-	TS5Z	
BT40-KHC16-90	●	BT40	16	38	50	44	90	SHC080150	SHE100130	-	TS5Z	
BT40-KHC18-90	●	BT40	18	40	50	45	90	SHC080150	SHE100130	-	TS5Z	
BT40-KHC20-90	●	BT40	20	42	50	49	90	SHC080150	SHE100130	HC20	TS5Z	
BT40-KHC20-140	●	BT40	20	42	50	99	140	SHC080150	SHE100130	HC20	TS5Z	
BT40-KHC25-100	●	BT40	25	57	66	57	100	SHC080150	SHE100130	-	TS5Z	
BT40-KHC32-105	●	BT40	32	64	75	61	105	SHC100150	SHE100130	HC32	TS5Z	

订货示例: BT40-KHC06-90  
Order example: BT40-KHC06-90

- 最小夹持深度详见27页

● 常备库存  
Unallocated stock

◐ 可备库存  
Available stock

○ 订单生产  
Order production

# D 工具系统 Tool System

## 液压夹头刀柄-BT50 Hydraulic Chucks

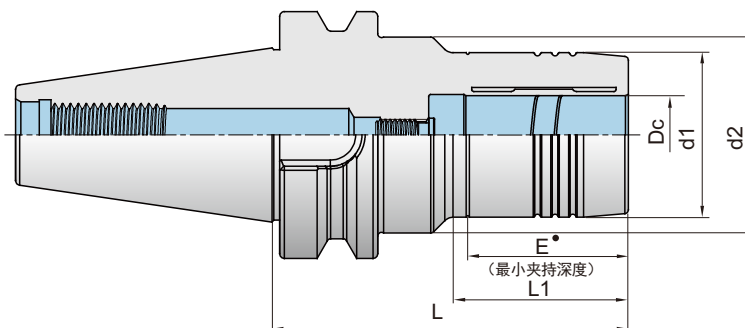
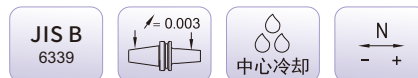

型号 Type	库存 Stock	锥柄型式 Taper type	尺寸(mm) Dimension					轴向调节螺钉 Axial adjustment screw	加压螺钉 Locking Screw	卡簧 HC collet	扳手 Wrench	重量 (kg)
			Dc	d1	d2	L1	L					
BT50-KHC06-90	●	BT50	6	26	50	31	90	SHC050150	SHE100130	-	TS5Z	
BT50-KHC08-90	●	BT50	8	30	50	33	90	SHC060150	SHE100130	-	TS5Z	
BT50-KHC10-95	●	BT50	10	32	50	36	95	SHC080150	SHE100130	-	TS5Z	
BT50-KHC12-100	●	BT50	12	34	50	41	100	SHC080150	SHE100130	HC12	TS5Z	
BT50-KHC14-100	●	BT50	14	36	50	42	100	SHC080150	SHE100130	-	TS5Z	
BT50-KHC16-100	●	BT50	16	38	50	43	100	SHC080150	SHE100130	-	TS5Z	
BT50-KHC18-100	●	BT50	18	40	50	45	100	SHC080150	SHE100130	-	TS5Z	
BT50-KHC20-105	●	BT50	20	42	50	51	105	SHC080150	SHE100130	HC20	TS5Z	
BT50-KHC20-140	●	BT50	20	42	50	86	140	SHC080150	SHE100130	HC20	TS5Z	
BT50-KHC25-110	●	BT50	25	57	66	58	110	SHC080150	SHE100130	-	TS5Z	
BT50-KHC32-115	●	BT50	32	64	75	62	115	SHC100150	SHE100130	HC32	TS5Z	

订货示例: BT50-KHC06-90  
Order example: BT50-KHC06-90

- 最小夹持深度详见27页

● 常备库存  
Unallocated stock

◐ 可备库存  
Available stock

○ 订单生产  
Order production

# D 工具系统 Tool System

液压夹头刀柄-BBT30  
Hydraulic Chucks

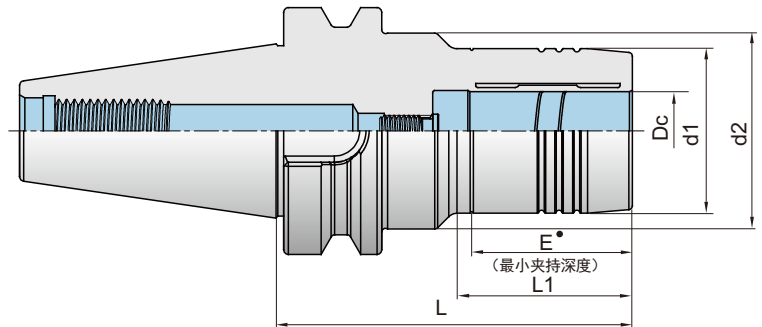
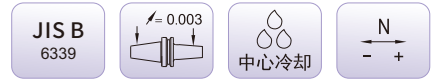

型号 Type	库存 Stock	锥柄型式 Taper type	尺寸(mm) Dimension					轴向调节螺钉 Axial adjustment screw	加压螺钉 Locking Screw	卡簧 HC collet	扳手 Wrench	重量 (kg)
			Dc	d1	d2	L1	L					
BBT30-KHC06-75	●	BBT30	6	26	50	30	75	SHC050150	SHE100130	-	TS5Z	
BBT30-KHC08-75	●	BBT30	8	30	50	31	75	SHC060150	SHE100130	-	TS5Z	
BBT30-KHC10-80	●	BBT30	10	32	50	37	80	SHC080150	SHE100130	-	TS5Z	
BBT30-KHC12-85	●	BBT30	12	34	50	42	85	SHC080150	SHE100130	HC12	TS5Z	
BBT30-KHC16-90	●	BBT30	16	38	50	49	90	SHC080150	SHE100130	-	TS5Z	
BBT30-KHC20-90	●	BBT30	20	42	50	51	90	SHC080150	SHE100130	HC20	TS5Z	

➔ 订货示例: BBT30-KHC06-75  
Order example: BBT30-KHC06-75

● 最小夹持深度详见27页

● 常备库存  
Unallocated stock

● 可备库存  
Available stock

○ 订单生产  
Order production

# D 工具系统 Tool System

液压夹头刀柄-BBT40  
Hydraulic Chucks

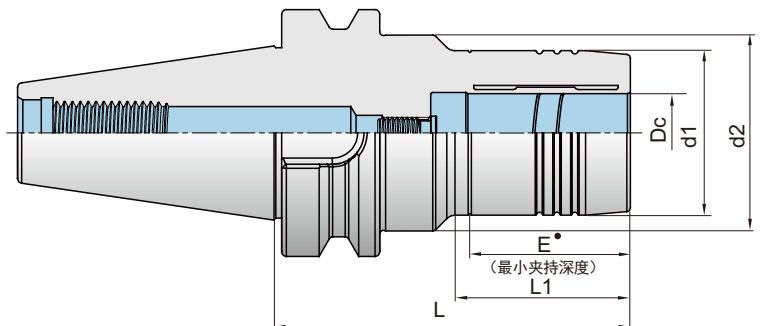
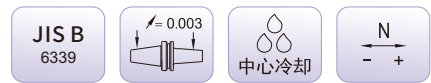

型号 Type	库存 Stock	锥柄型式 Taper type	尺寸(mm) Dimension					轴向调节螺钉 Axial adjustment screw	加压螺钉 Locking Screw	卡簧 HC collet	扳手 Wrench	重量 (kg)
			Dc	d1	d2	L1	L					
BBT40-KHC06-90	●	BBT40	6	26	50	36	90	SHC050150	SHE100130	-	TS5Z	
BBT40-KHC08-90	●	BBT40	8	30	50	40	90	SHC060150	SHE100130	-	TS5Z	
BBT40-KHC10-90	●	BBT40	10	32	50	41	90	SHC080150	SHE100130	-	TS5Z	
BBT40-KHC12-90	●	BBT40	12	34	50	42	90	SHC080150	SHE100130	HC12	TS5Z	
BBT40-KHC14-90	●	BBT40	14	36	50	43	90	SHC080150	SHE100130	-	TS5Z	
BBT40-KHC16-90	●	BBT40	16	38	50	44	90	SHC080150	SHE100130	-	TS5Z	
BBT40-KHC18-90	●	BBT40	18	40	50	45	90	SHC080150	SHE100130	-	TS5Z	
BBT40-KHC20-90	●	BBT40	20	42	50	49	90	SHC080150	SHE100130	HC20	TS5Z	
BBT40-KHC25-100	●	BBT40	25	57	66	57	100	SHC080150	SHE100130	-	TS5Z	
BBT40-KHC32-105	●	BBT40	32	64	75	61	105	SHC100150	SHE100130	HC32	TS5Z	

订货示例: BBT40-KHC06-90  
Order example: BBT40-KHC06-90

- 最小夹持深度详见27页

● 常备库存  
Unallocated stock

◐ 可备库存  
Available stock

○ 订单生产  
Order production

# D 工具系统 Tool System

液压夹头刀柄-BBT50  
Hydraulic Chucks

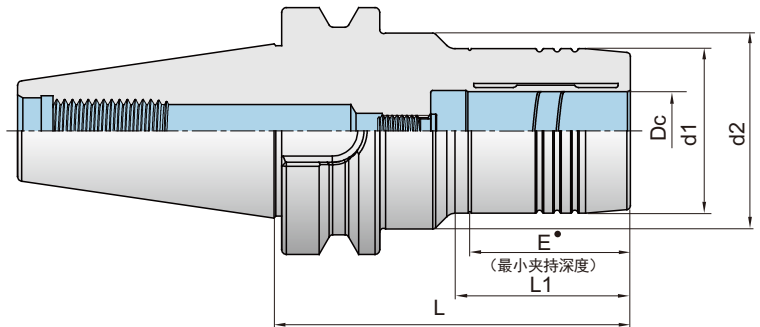
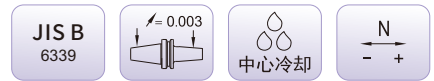

型号 Type	库存 Stock	锥柄型式 Taper type	尺寸(mm) Dimension					轴向调节螺钉 Axial adjustment screw	加压螺钉 Locking Screw	卡簧 HC collet	扳手 Wrench	重量 (kg)
			Dc	d1	d2	L1	L					
BBT50-KHC06-90	●	BBT50	6	26	50	31	90	SHC050150	SHE100130	-	TS5Z	
BBT50-KHC08-90	●	BBT50	8	30	50	33	90	SHC060150	SHE100130	-	TS5Z	
BBT50-KHC10-95	●	BBT50	10	32	50	36	95	SHC080150	SHE100130	-	TS5Z	
BBT50-KHC12-100	●	BBT50	12	34	50	41	100	SHC080150	SHE100130	HC12	TS5Z	
BBT50-KHC14-100	●	BBT50	14	36	50	42	100	SHC080150	SHE100130	-	TS5Z	
BBT50-KHC16-100	●	BBT50	16	38	50	43	100	SHC080150	SHE100130	-	TS5Z	
BBT50-KHC18-100	●	BBT50	18	40	50	45	100	SHC080150	SHE100130	-	TS5Z	
BBT50-KHC20-105	●	BBT50	20	42	50	51	105	SHC080150	SHE100130	HC20	TS5Z	
BBT50-KHC25-110	●	BBT50	25	57	66	58	110	SHC080150	SHE100130	-	TS5Z	
BBT50-KHC32-115	●	BBT50	32	64	75	62	115	SHC100150	SHE100130	HC32	TS5Z	

订货示例: BBT50-KHC06-90  
Order example: BBT50-KHC06-90

- 最小夹持深度详见27页

● 常备库存  
Unallocated stock

◐ 可备库存  
Available stock

○ 订单生产  
Order production

# D 工具系统 Tool System

液压夹头刀柄-JT40  
Hydraulic Chucks

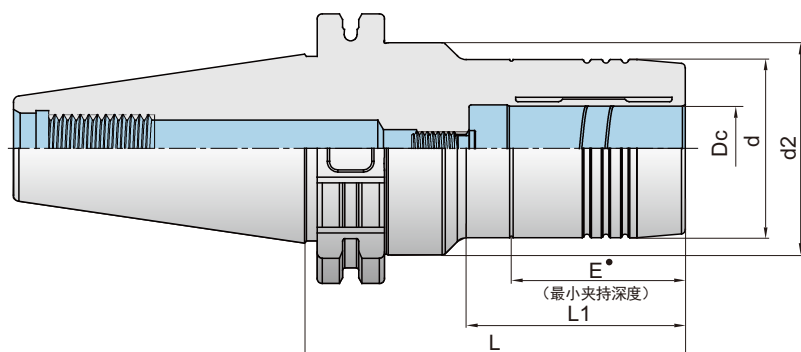
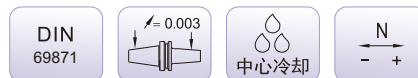

型号 Type	库存 Stock	锥柄型式 Taper type	尺寸(mm) Dimension					轴向调节螺钉 Axial adjustment screw	加压螺钉 Locking Screw	卡簧 HC collet	扳手 Wrench	重量 (kg)
			Dc	d1	d2	L1	L					
JT40-KHC06-80	●	JT40	6	26	50	35	80	SHC050150	SHE100130	-	TS5Z	
JT40-KHC08-80	●	JT40	8	30	50	37	80	SHC060150	SHE100130	-	TS5Z	
JT40-KHC10-80	●	JT40	10	32	50	38	80	SHC080150	SHE100130	-	TS5Z	
JT40-KHC12-80	●	JT40	12	34	50	39	80	SHC080150	SHE100130	HC12	TS5Z	
JT40-KHC16-80	●	JT40	16	38	50	44	80	SHC080150	SHE100130	-	TS5Z	
JT40-KHC20-90	●	JT40	20	42	50	53	90	SHC080150	SHE100130	HC20	TS5Z	
JT40-KHC25-110	●	JT40	25	57	66	54	110	SHC080150	SHE100130	-	TS5Z	
JT40-KHC32-115	●	JT40	32	64	75	57	115	SHC100150	SHE100130	HC32	TS5Z	

订货示例: JT40-KHC06-80  
Order example: JT40-KHC06-80  
● 最小夹持深度详见27页

● 常备库存 Unallocated stock    ● 可备库存 Available stock    ○ 订单生产 Order production

# D 工具系统 Tool System

液压夹头刀柄-JT50  
Hydraulic Chucks

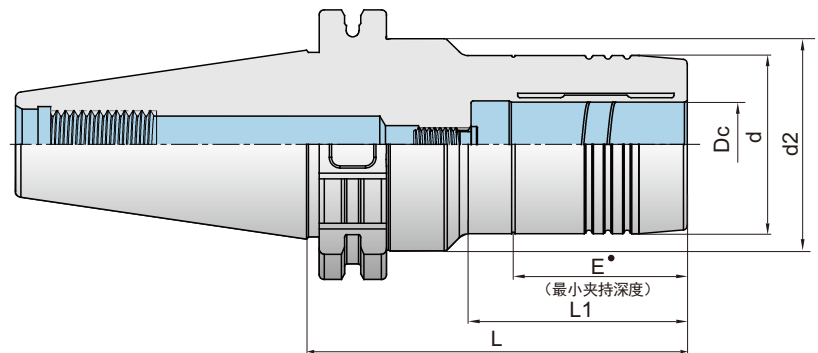
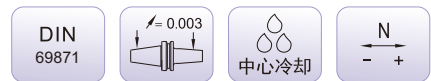

型号 Type	库存 Stock	锥柄型式 Taper type	尺寸(mm) Dimension					轴向调节螺钉 Axial adjustment screw	加压螺钉 Locking Screw	卡簧 HC collet	扳手 Wrench	重量 (kg)
			Dc	d1	d2	L1	L					
JT50-KHC06-90	●	JT50	6	26	50	40	90	SHC050150	SHE100130	-	TS5Z	
JT50-KHC08-90	●	JT50	8	30	50	47	90	SHC060150	SHE100130	-	TS5Z	
JT50-KHC10-90	●	JT50	10	32	50	48	90	SHC080150	SHE100130	-	TS5Z	
JT50-KHC12-90	●	JT50	12	34	50	49	90	SHC080150	SHE100130	HC12	TS5Z	
JT50-KHC16-90	●	JT50	16	38	50	51	90	SHC080150	SHE100130	-	TS5Z	
JT50-KHC20-90	●	JT50	20	42	50	53	90	SHC080150	SHE100130	HC20	TS5Z	
JT50-KHC25-90	●	JT50	25	57	66	52	90	SHC080150	SHE100130	-	TS5Z	
JT50-KHC32-100	●	JT50	32	64	75	63	100	SHC100150	SHE100130	HC32	TS5Z	

订货示例: JT50-KHC06-90  
Order example: JT50-KHC06-90  
• 最小夹持深度详见27页

● 常备库存 Unallocated stock    ● 可备库存 Available stock    ○ 订单生产 Order production

# ● 液压夹头刀柄

液压夹头刀柄-细长型

HSK63A

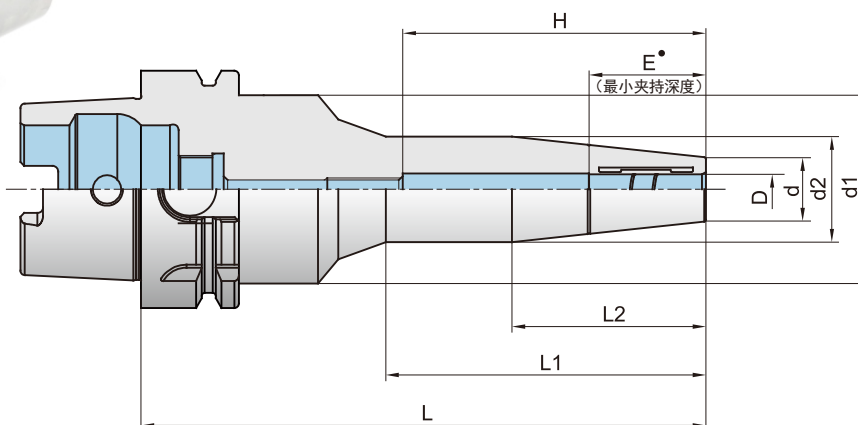
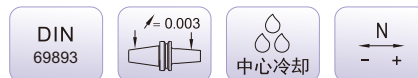

型号 Type	库存 Stock	锥柄型式 Taper type	尺寸(mm) Dimension								加压螺钉 Locking Screw	卡簧 HC collet	扳手 Wrench	重量 (kg)
			D	d	d1	d2	L	L1	L2	H				
HSK63A-KHC06S-150	●	HSK63A	6	14	48	26	150	85	56	80	SHE100110	-	TS5Z	
HSK63A-KHC08S-150	●	HSK63A	8	17	48	28	150	85	52	80	SHE100130	-	TS5Z	
HSK63A-KHC10S-150	●	HSK63A	10	19	48	30	150	85	52	82	SHE100130	-	TS5Z	
HSK63A-KHC12S-150	●	HSK63A	12	21	48	32	150	85	52	86	SHE100130	HC12	TS5Z	

➔ 订货示例: HSK63A-KHC06S-150  
Order example: HSK63A-KHC06S-150

● 常备库存  
Unallocated stock

● 可备库存  
Available stock

○ 订单生产  
Order production

- 最小夹持深度详见27页

# ● 液压夹头刀柄

## 液压夹头刀柄-细长型

BT30

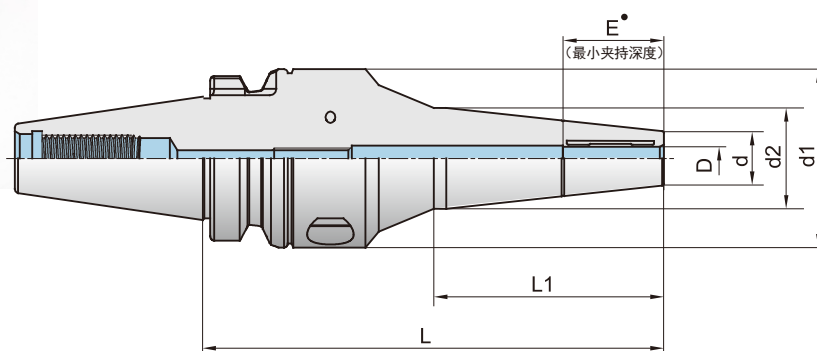

型号 Type	库存 Stock	锥柄型式 Taper type	尺寸(mm) Dimension						加压螺钉 Locking Screw	卡簧 HC collet	扳手 Wrench	重量 (kg)
			D	d	d1	d2	L	L1				
BT30-KHC06S-120	●	BT30	6	14	46	26	120	68	SHE100110	-	TS5Z	
BT30-KHC08S-120	●	BT30	8	17	46	28	120	68	SHE100130	-	TS5Z	
BT30-KHC10S-120	●	BT30	10	19	46	30	120	68	SHE100130	-	TS5Z	
BT30-KHC12S-120	●	BT30	12	21	46	32	120	68	SHE100130	HC12	TS5Z	

➔ 订货示例: BT30-KHC06S-120  
Order example: BT30-KHC06S-120

● 常备库存  
Unallocated stock

● 可备库存  
Available stock

○ 订单生产  
Order production

- 最小夹持深度详见27页

# ● 液压夹头刀柄

## 液压夹头刀柄-细长型

BT40

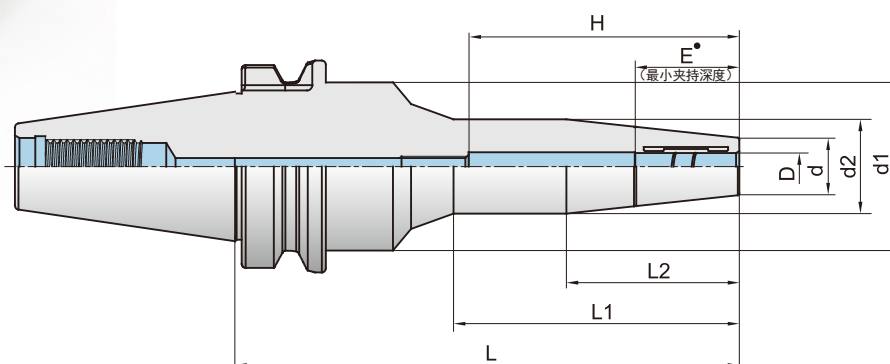

型号 Type	库存 Stock	锥柄型式 Taper type	尺寸(mm) Dimension								加压螺钉 Locking Screw	卡簧 HC collet	扳手 Wrench	重量 (kg)
			D	d	d1	d2	L	L1	L2	H				
BT40-KHC06S-150	●	BT40	6	14	48	26	150	85	56	80	SHE100110	-	TS5Z	
BT40-KHC08S-150	●	BT40	8	17	50	28	150	85	52	80	SHE100130	-	TS5Z	
BT40-KHC10S-150	●	BT40	10	19	50	30	150	85	52	82	SHE100130	-	TS5Z	
BT40-KHC12S-150	●	BT40	12	21	50	32	150	85	52	86	SHE100130	HC12	TS5Z	

➔ 订货示例: BT40-KHC06S-150  
Order example: BT40-KHC06S-150

● 常备库存  
Unallocated stock

◐ 可备库存  
Available stock

○ 订单生产  
Order production

- 最小夹持深度详见27页

# ● 液压夹头刀柄

## 液压夹头刀柄-细长型

BBT30

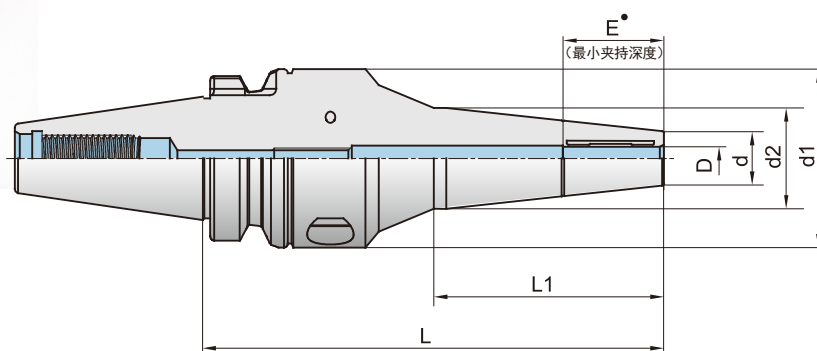

型号 Type	库存 Stock	锥柄型式 Taper type	尺寸(mm) Dimension						加压螺钉 Locking Screw	卡簧 HC collet	扳手 Wrench	重量 (kg)
			D	d	d1	d2	L	L1				
BBT30-KHC06S-120	●	BBT30	6	14	46	26	120	68	SHE100110	-	TS5Z	
BBT30-KHC08S-120	●	BBT30	8	17	46	28	120	68	SHE100130	-	TS5Z	
BBT30-KHC10S-120	●	BBT30	10	19	46	30	120	68	SHE100130	-	TS5Z	
BBT30-KHC12S-120	●	BBT30	12	21	46	32	120	68	SHE100130	HC12	TS5Z	

➔ 订货示例: BBT30-KHC06S-120  
Order example: BBT30-KHC06S-120

● 常备库存  
Unallocated stock

● 可备库存  
Available stock

○ 订单生产  
Order production

- 最小夹持深度详见27页

# ● 液压夹头刀柄

## 液压夹头刀柄-细长型

BBT40

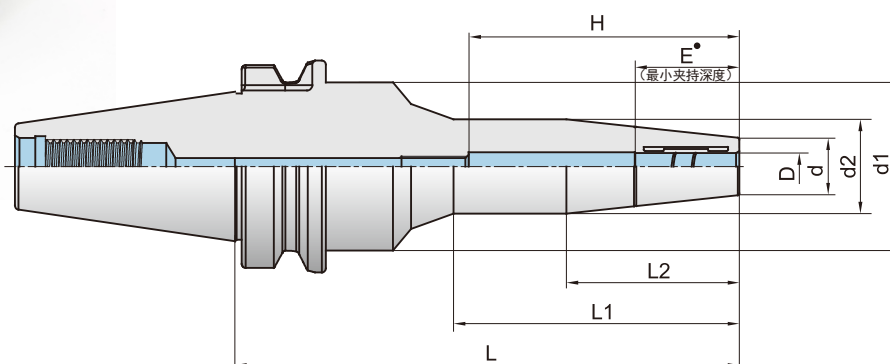

型号 Type	库存 Stock	锥柄型式 Taper type									加压螺钉 Locking Screw	卡簧 HC collet	扳手 Wrench	重量 (kg)
			D	d	d1	d2	L	L1	L2	H				
BBT40-KHC06S-150	●	BBT40	6	14	48	26	150	85	56	80	SHE100110	-	TS5Z	
BBT40-KHC08S-150	●	BBT40	8	17	50	28	150	85	52	80	SHE100130	-	TS5Z	
BBT40-KHC10S-150	●	BBT40	10	19	50	30	150	85	52	82	SHE100130	-	TS5Z	
BBT40-KHC12S-150	●	BBT40	12	21	50	32	150	85	52	86	SHE100130	HC12	TS5Z	

➔ 订货示例: BBT40-KHC06S-150  
Order example: BBT40-KHC06S-150

● 常备库存  
Unallocated stock

◐ 可备库存  
Available stock

○ 订单生产  
Order production

- 最小夹持深度详见27页

# ● 液压夹头刀柄

走心机

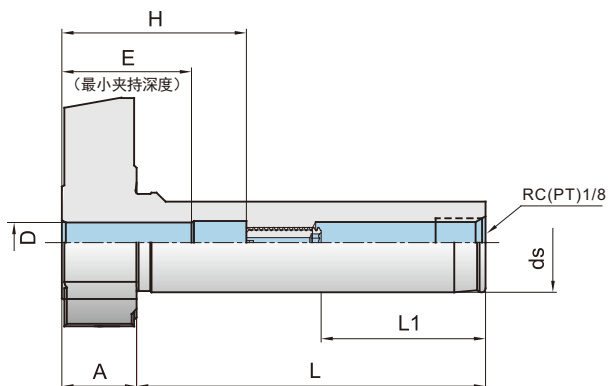
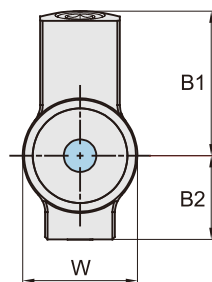

型号 Type	库存 Stock	尺寸(mm) Dimension								H	E	轴向调节螺钉 Axial adjustment screw	重量 (kg)
		D	ds	L	L1	A	B1	B2	W				
B19.05-KHC04-60	○	4	19.05	60	30	15	27	16.8	22	32	20	SGC040160C	
B19.05-KHC06-60	○	6	19.05	60	30	15	27	16.8	22	-	25	-	
B19.05-HDC08-60	○	8	19.05	60	30	15	29	16.8	22	-	31	-	
B20-KHC04-70	●	4	20	70	40	15	27	16.8	23	32	20	SGC040160C	
B20-KHC06-70	●	6	20	70	40	15	27	16.8	23	48	25	SGC050250C	
B20-KHC08-70	●	8	20	70	40	15	29	16.8	23	-	31	-	
B22-KHC04-70	○	4	22	70	40	15	27	16.8	25	32	20	SGC040160C	
B22-KHC06-70	○	6	22	70	40	15	27	16.8	25	-	25	-	
B22-KHC08-70	○	8	22	70	40	15	29	16.8	25	-	31	-	
B22-KHC10-70	○	10	22	70	40	15	30	17.8	25	-	31	-	

➔ 订货示例: B19.05-KHC04-60  
Order example: B19.05-KHC04-60

● 常备库存  
Unallocated stock

○ 可备库存  
Available stock

○ 订单生产  
Order production

# ● 液压夹头刀柄

走心机

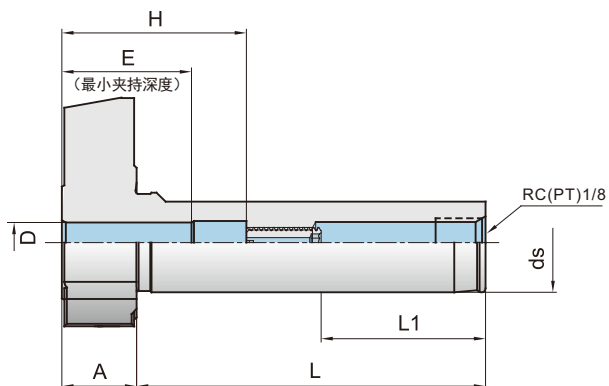
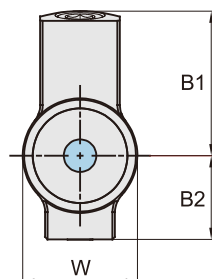

型号 Type	库存 Stock	尺寸(mm) Dimension								H	E	轴向调节螺钉 Axial adjustment screw	重量 (kg)
		D	ds	L	L1	A	B1	B2	W				
B25-KHC04-65	●	4	25	65	25	15	27	16.8	28	32	20	SGC040160C	
B25-KHC06-65	●	6	25	65	25	15	27	16.8	28	48	25	SGC050250C	
B25-KHC08-65	●	8	25	65	25	15	29	16.8	28	-	31	-	
B25-KHC10-65	●	10	25	65	25	15	30	17.8	28	-	31	-	
B25-KHC12-65	●	12	25	65	25	15	31	18.8	28	-	36	-	
										-			
B25.4-KHC04-80	●	4	25.4	80	40	15	27	16.8	28	32	20	SGC040160C	
B25.4-KHC06-80	●	6	25.4	80	40	15	27	16.8	28	48	25	SGC050250C	
B25.4-KHC08-80	●	8	25.4	80	40	15	29	16.8	28	-	31	-	
B25.4-KHC10-80	●	10	25.4	80	40	15	30	17.8	28	-	31	-	
B25.4-KHC12-80	●	12	25.4	80	40	15	31	18.8	28	-	36	-	

➔ 订货示例: B25-KHC04-65  
Order example: B25-KHC04-65

● 常备库存  
Unallocated stock

● 可备库存  
Available stock

○ 订单生产  
Order production

## ● 液压夹头刀柄

液压夹头刀柄-XME  
Hydraulic Chucks

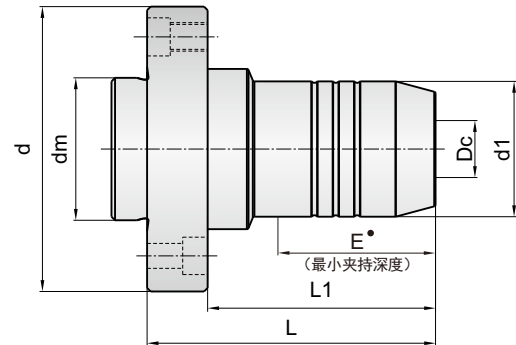
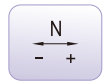

型号 Type	库存 Stock	法兰型式 Taper type	尺寸(mm) Dimension						螺钉 Screw	扳手 Wrench	扳手 Wrench	重量 (kg)
			dm	d	Dc	d1	L1	L				
XME30T-KHC06-65	●	XME30T	30	60	6	26	52	65	SFD080080	S4	TS5Z	
XME30T-KHC08-65	●	XME30T	30	60	8	30	52	65	SFD080080	S4	TS5Z	
XME30T-KHC10-70	●	XME30T	30	60	10	32	57	70	SFD080080	S4	TS5Z	
XME30T-KHC12-75	●	XME30T	30	60	12	34	62	75	SFD080080	S4	TS5Z	
XME40T-KHC12-77.5	●	XME40T	40	80	12	34	60.5	77.5	SFD080120	S4	TS5Z	
XME40T-KHC16-82.5	●	XME40T	40	80	16	38	65.5	82.5	SFD080120	S4	TS5Z	
XME40T-KHC20-82.5	●	XME40T	40	80	20	42	65.5	82.5	SFD080120	S4	TS5Z	
XME50T-KHC25-100	○	XME50T	50	100	25	57	79	100	SFE100140	S5	TS5Z	
XME60T-KHC32-103	○	XME60T	60	117	32	64	82	103	SFE100140	S5	TS5Z	

▶ 订货示例:XME30T-KHC06-65  
Order example:XME30T-KHC06-65

● 常备库存  
Unallocated stock

◐ 可备库存  
Available stock

○ 订单生产  
Order production

- 最小夹持深度详见27页

# ● 液压夹头刀柄

液压卡簧 (内冷)  
Hydraulic Collet



液压刀柄卡簧编号规则:

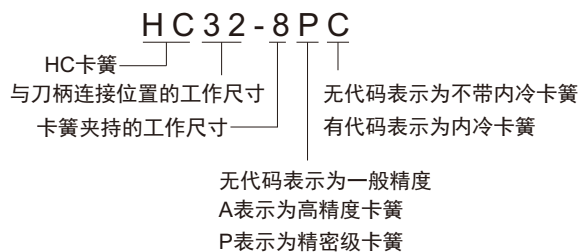

夹持精度:

夹持直径 Holding dia.	径向跳动 Run out		
	一般精度 General accuracy	高精度A High precision	精密级P Ultrahigh precision
3-25	0.008	0.005	0.003

P级卡簧  
2.5D跳动0.003

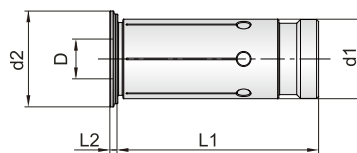

内冷卡簧 Coolant collet	库存 Stock	尺寸(mm) Dimension					重量 (kg)
		D	d1	d2	L1	L2	
HC12-3PC	●	3	12	16.5	45	2	0.05
HC12-4PC	●	4	12	16.5	45	2	0.05
HC12-5PC	●	5	12	16.5	45	2	0.05
HC12-6PC	●	6	12	16.5	45	2	0.05
HC12-8PC	●	8	12	16.5	45	2	0.05
HC20-3PC	●	3	20	24.1	50.5	2	0.1
HC20-4PC	●	4	20	24.1	50.5	2	0.1
HC20-5PC	●	5	20	24.1	50.5	2	0.1
HC20-6PC	●	6	20	24.1	50.5	2	0.1
HC20-8PC	●	8	20	24.1	50.5	2	0.1
HC20-9PC	●	9	20	24.1	50.5	2	0.1
HC20-10PC	●	10	20	24.1	50.5	2	0.1
HC20-12PC	●	12	20	24.1	50.5	2	0.1
HC20-14PC	●	14	20	24.1	50.5	2	0.1
HC20-15PC	●	15	20	24.1	50.5	2	0.1
HC20-16PC	●	16	20	24.1	50.5	2	0.1
HC32-8PC	●	8	32	35.5	60.5	2	0.28
HC32-10PC	●	10	32	35.5	60.5	2	0.28
HC32-12PC	●	12	32	35.5	60.5	2	0.28
HC32-14PC	●	14	32	35.5	60.5	2	0.28
HC32-16PC	●	16	32	35.5	60.5	2	0.28
HC32-18PC	●	18	32	35.5	60.5	2	0.28
HC32-20PC	●	20	32	35.5	60.5	2	0.28
HC32-25PC	●	25	32	35.5	60.5	2	0.28

➔ 订货示例: HC20-6PC

# ● 液压夹头刀柄

## 应用资料

### Application Data

#### 夹紧&松开

- 夹紧时保证刀柄和刀具无毛刺、污垢。
- 用内六角扳手手动拧夹紧螺钉。
- 缓劲拧动夹紧螺钉，切勿使用电、气动螺丝刀。
- 液压刀具不能空压（不能在未装夹刀具或工件时拧紧夹紧螺钉）。

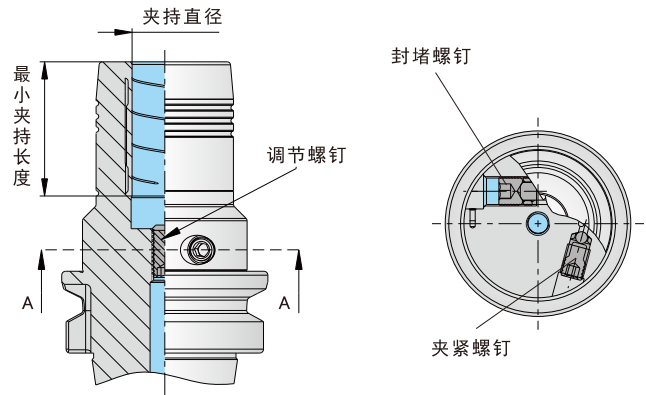

#### 夹紧力控制

以下三种情况下需要重新校核夹紧力。

- 第一次使用时；
- 使用超过100次以上；
- 每三个月至少校核一次。

校核需使用专用的测试轴，插入刀柄深度不小于最小夹持深度。当环境温度在20°C-25°C时，拧紧螺钉至刀具刚好不能拔出，如不能继续拧紧螺钉指定圈数以上，那么刀柄就不能继续使用。建议刀柄返厂维修。



**注意** 夹紧时必须使用有机溶剂（酒精等）去除夹持面上油渍，油渍会使夹持力骤降，导致严重加工事故。

测试轴型号	夹持尺寸	最小拧紧圈数
JHXB-KHC06	6	1.5
JHXB-KHC08	8	1.5
JHXB-KHC10	10	1.5
JHXB-KHC12	12	2
JHXB-KHC14	14	2
JHXB-KHC16	16	2
JHXB-KHC18	18	2
JHXB-KHC20	20	3
JHXB-KHC25	25	3
JHXB-KHC32	32	3

#### 夹持长度控制

- 可通过限位螺钉调节刀具的夹持长度，一方面防止刀具触底，影响刀具夹持精度；另一方面防止夹持长度不够，影响刀具的夹紧扭矩。

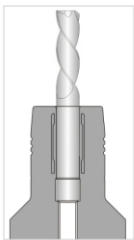

刀具触碰底部

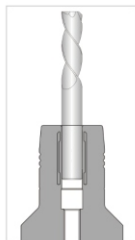

刀具插入深度小于最小夹持长度

#### 动平衡指标

- 标准平衡精度见下表

柄部型式	推荐动平衡值
BT30/40/50	G6.3 15000转/分
BBT30/40/50	G6.3 15000转/分
JT30/40/50	G6.3 15000转/分
HSK-A 32-63	G6.3 15000转/分
HSK-A 80-100	G6.3 12000转/分
HSK-C 32-63	G6.3 15000转/分
HSK-C 80-100	G6.3 12000转/分
HSK-E 32-63	G6.3 30000转/分

- 更高平衡精度需订货时说明。

# ● 液压夹头刀柄

## 应用资料

### Application Data

#### 可夹持刀柄型式

- 型式A: 圆柱柄 (DIN1835-Form A)
- 型式B: 带扁的圆柱柄 (DIN1835-Form B)
- 型式C: 2°侧固式刀柄 (DIN1835-Form E)

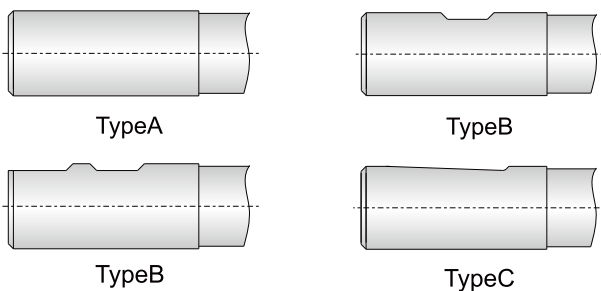

型式B和C推荐使用液压卡簧，不建议直接夹持。

#### 刀柄过热注意

- 大余量或连续切削时采用充分的切削液或压缩空气连续、直接冷却液压刀柄夹持部位，避免使用过程中过热。
- 刀柄的最佳工作温度20°C~50°C，最高不超过80°C，最低不低于10°C。

过高的温度会导致液压刀柄内部压力超过设计的最大值甚至导致刀柄开裂。过低的温度会导致液压刀柄内部压力不足无法有效夹紧刀具。

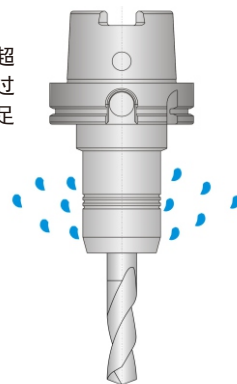

#### 基本参数

孔径 (mm)	Max.rpm		最小扭矩(NM)			最小夹持 深度 E	容许径向力N 悬长50mm处	刀具柄径 (mm)
	L1≤125	L1>125	细长型	标准型*	强力型			
Φ4	40000	20000	3	5	-	19	-	5 h6
Φ6	40000	20000	10	12	-	27	225	6 h6
Φ8	40000	20000	23	20	-	27	370	8 h6
Φ10	40000	20000	40	46	-	31	540	10 h6
Φ12	40000	20000	65	75	110	36	650	12 h6
Φ14	40000	20000	-	98	-	36	900	14 h6
Φ16	40000	20000	-	160	350	39	1410	16 h6
Φ18	40000	20000	-	210	-	39	1580	18 h6
Φ20	40000	20000	-	280	520	41	1860	20 h6
Φ25	15000	10000	-	450	-	47	4400	25 h6
Φ32	15000	10000	-	700	900	51	6500	32 h6

- 为保证机床精度和寿命，动平衡精度不低于G6.3。
- 标准型包括车床、走心机专用液压刀柄。

#### 液压卡簧扭矩值

- 以下数据是在实测基础上，并考虑了一定的安全系数给出的。  
被测刀杆为光滑圆柱体，尺寸精度为h6的极限下差。

刀柄 孔径 (mm)	液压卡簧(mm)																		最小 夹持 扭矩 N.M
	3	4	5	6	7	8	9	10	11	12	13	14	15	16	17	18	20	25	
12	4	5	7	12	-	15	-	-	-	-	-	-	-	-	-	-	-	-	最小夹持扭矩 N.M
20	6	10	16	28	45	50	70	80	100	115	125	130	140	170	200	-	-	-	
32	-	-	-	36	-	46	-	82	-	120	-	140	-	200	-	260	280	400	



# 优秀产品与全方位服务的结合

Combination of excellent products and full services

## 我们帮助您实现:

- 生产周期的大幅缩短
- 生产效率的快速提高
- 机床利用率迅速提升
- 快速交货和最佳的产品技术
- 机床主轴精度的持久保持

What we can help you to achieve  
Significantly shorten the production cycle  
Rapidly increase the productivity  
Rapidly increase the machine utilization  
State-of-art metal-cutting technology  
Fast delivery and best manufacturing process



## 专业设备 专业技术 专业品质

Specialized equipment, Advanced technology, Excellent quality



高品质配件  
High quality accessories

可信赖的专业技术  
Expert technology

强大的定制方案解决能力  
Strong turn-key solutions

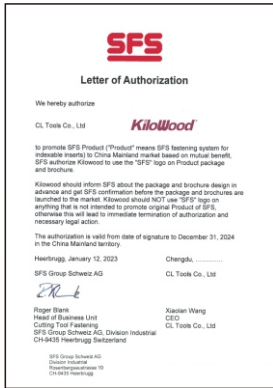

瑞士SFS授权书



WIHA授权书

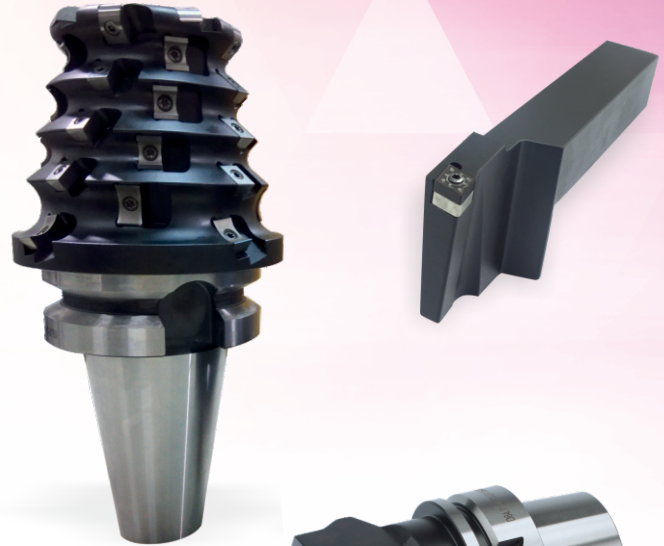

先进的项目设计理念  
专业的刀具配套方案  
卓越的非标刀具设计  
Advanced design concepts  
Professional tools selection  
Superior designing and manufacturing capabilities for special tools

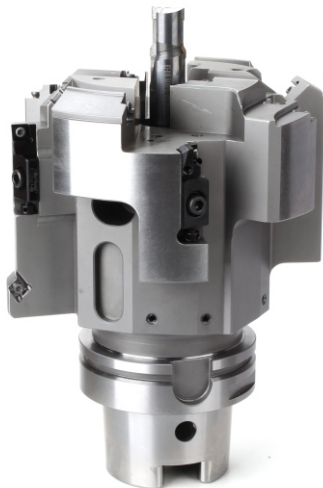

# Kilowood®

千木® | 包容、成长、希望…… |

## 成都成林数控刀具股份有限公司

地 址：成都市温江海峡两岸科技园蓉台大道7号

网 站：[www.kilowood.com](http://www.kilowood.com)

传 真：028-69920864

Ema i l：[kilowood@kilowood.com](mailto:kilowood@kilowood.com)

客户服务电话：

东 区：028-69920848

客户服务传真：028-69920864

山 东：028-69920863

南 区：028-69920847

技 术 服 务：028-69920862

西 区：028-69920851

028-69920856

北 区：028-69920845

028-69920866



KILOWOOD  
微信公众号



KILOWOOD  
网 站